



Brain Computer Interface Visualization for Human Electrocortical Biofeedback

Tiffany Phan, Zoya Ahmed, Thu Nguyen, Grace Byrne, Onyekachi N. James, Andrew D. Nordin (Ph.D.)
Department of Biomedical Engineering, University of Houston, Houston, TX



INTRODUCTION

- **Biofeedback** is used to provide a window into physiological processes that are otherwise not observable.
- **Brain computer interfaces** rely on electroencephalography (EEG) to non-invasively measure **electrical brain activity**.
- Electrocortical biofeedback can be used for studying **cortical adaptation** during neurorehabilitation.

Aim: to develop a physical model

METHODS

Hardware

- Circuit Design in Tinker CAD
- Simulation and Validation
- 3D Printed Head Phantom Design in Autodesk Fusion 360
- Prototype Assembly

Software

- Signal Processing of EEG Data in MATLAB
- Segmentation and PSD Analysis (Welch's Method)
- Normalization
- Band Selection Mode and Dominant Band Mode in Arduino IDE

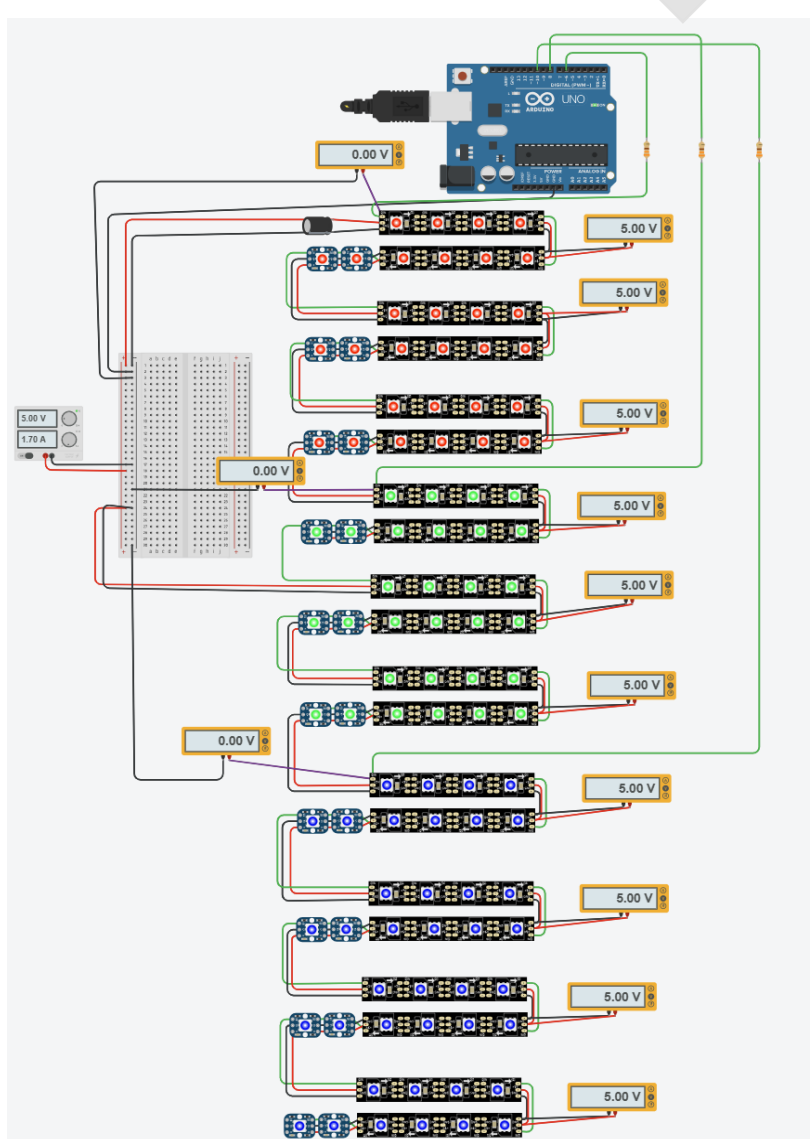

Figure 1. Circuit simulation in TinkerCad

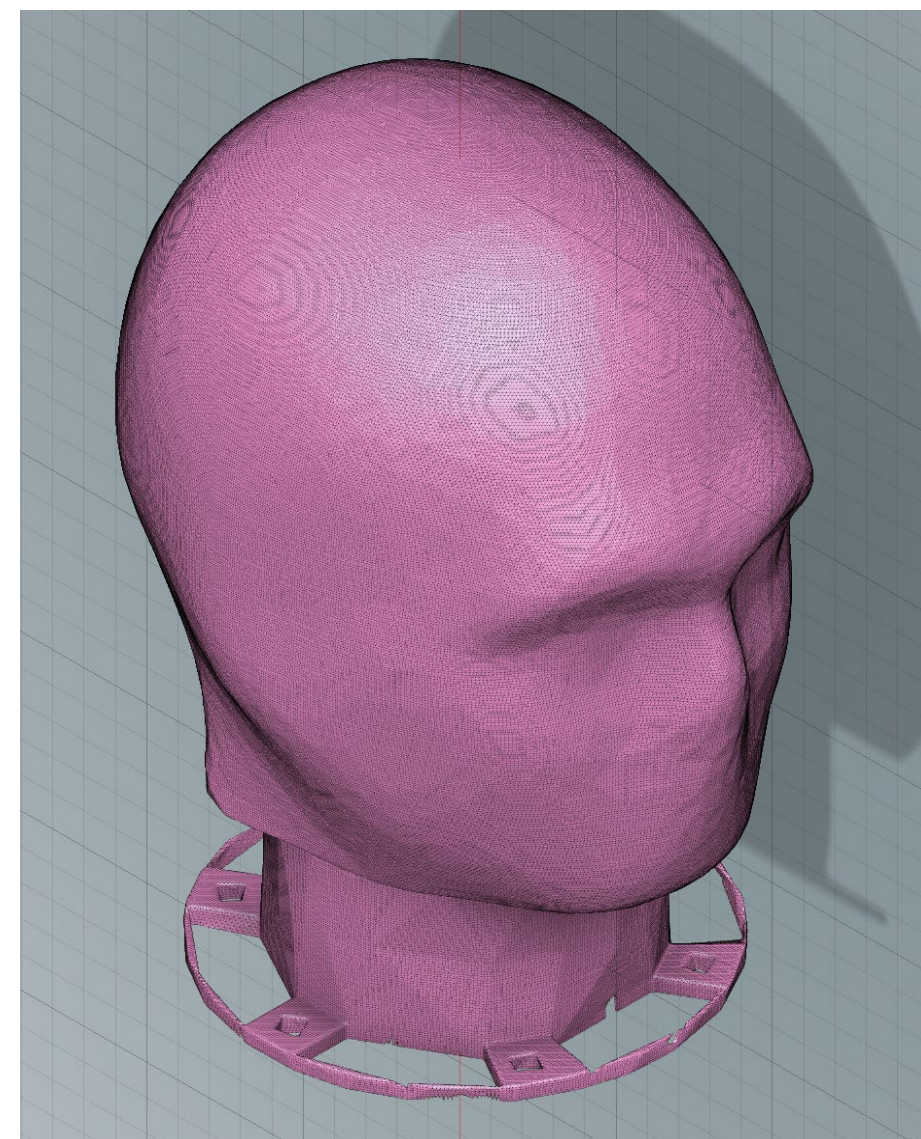

Figure 2. Design of head phantom in Autodesk Fusion 360

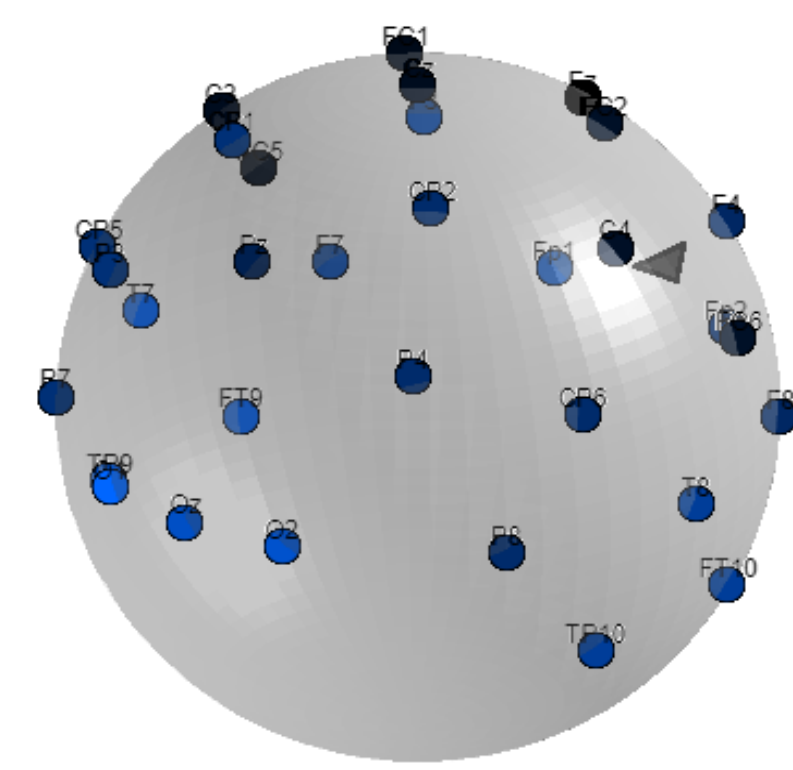

Figure 3. Band Selection Mode (Alpha) mapped on MATLAB

RESULTS & DISCUSSION

Region Mapping

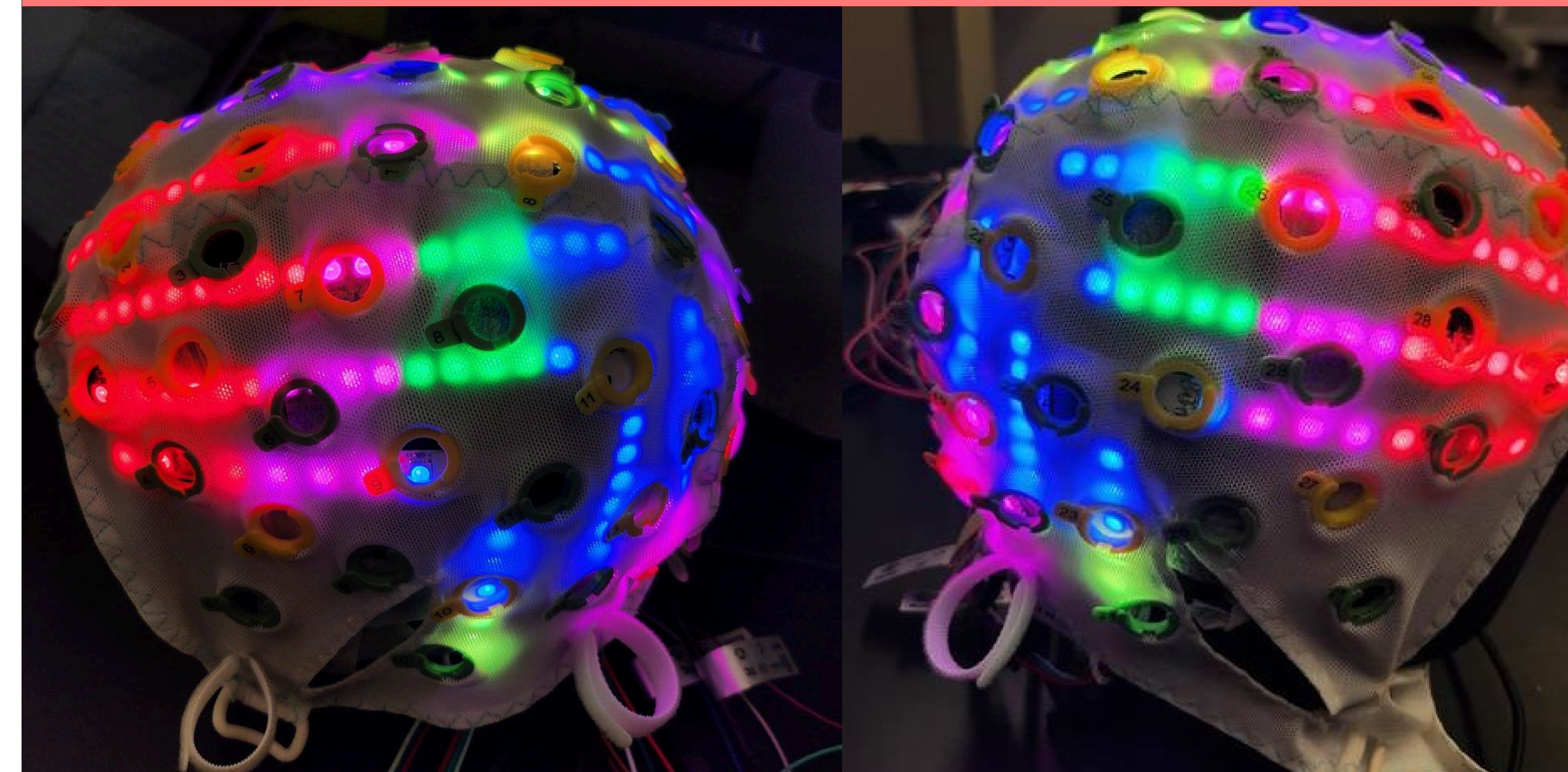

Figure 6. Spatial Mapping of LED Regions to Standardized EEG Electrode Locations. (a) left region, (b) right region

Band	Frequency Range (Hz)	LED Color
Delta	1-4	Red
Theta	4-8	Orange
Alpha	8-13	Blue
Beta	13-30	Green
Gamma	>30	Purple

Table 1. EEG Spectral Power Color Legend

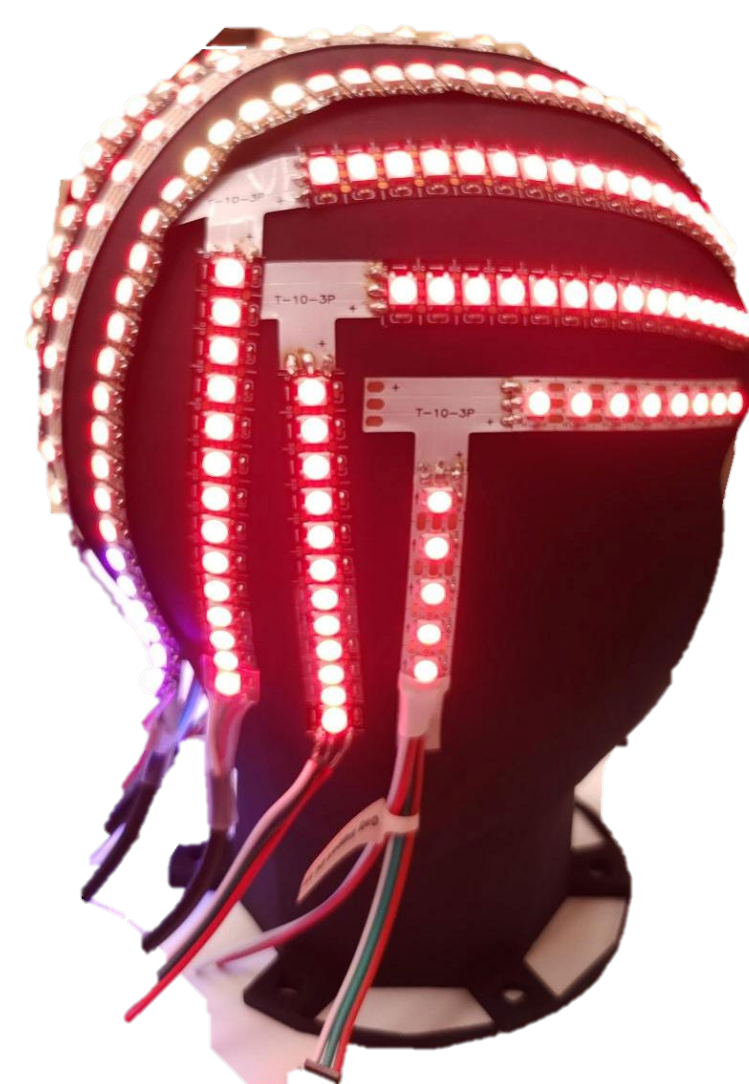

Figure 4. Final Prototype

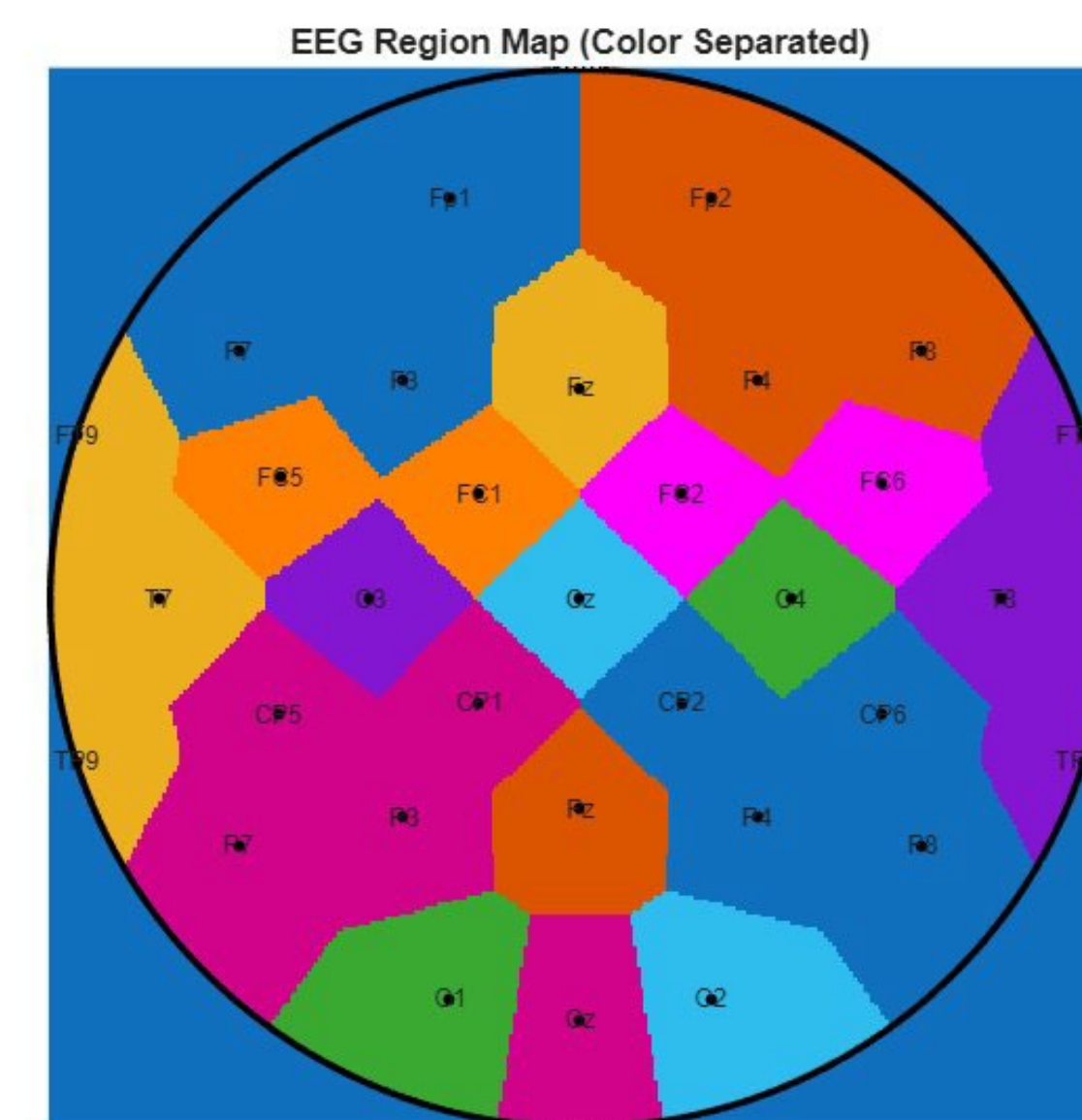

Figure 5. Mapping on MATLAB

The LED-based head phantom successfully translated EEG spectral power into intuitive LED-based spatial patterns, improving interpretability over conventional EEG visualizations. Regional light distributions matched expected neural activity, supporting the validity of the mapping approach. Overall, the system shows promise as an intuitive interface for real-time brain activity interpretation with applications in BCI training and diagnostics.

Visualization 1: Band Selection Mode



Figure 7. (a) Alpha band activity shown in blue, associated with relaxed wakefulness. (b) Theta band activity shown in orange linked to memory processing and early stage sleep

In Band Selection Mode, LED brightness represents normalized (min-max across regions) power within a selected frequency band. Higher left frontal alpha with lower frontocentral/central alpha and minimal frontocentral theta suggests reduced frontal engagement with increased cortical activation and an overall more alert cognitive state.

Visualization 2: Dominant Band Mode

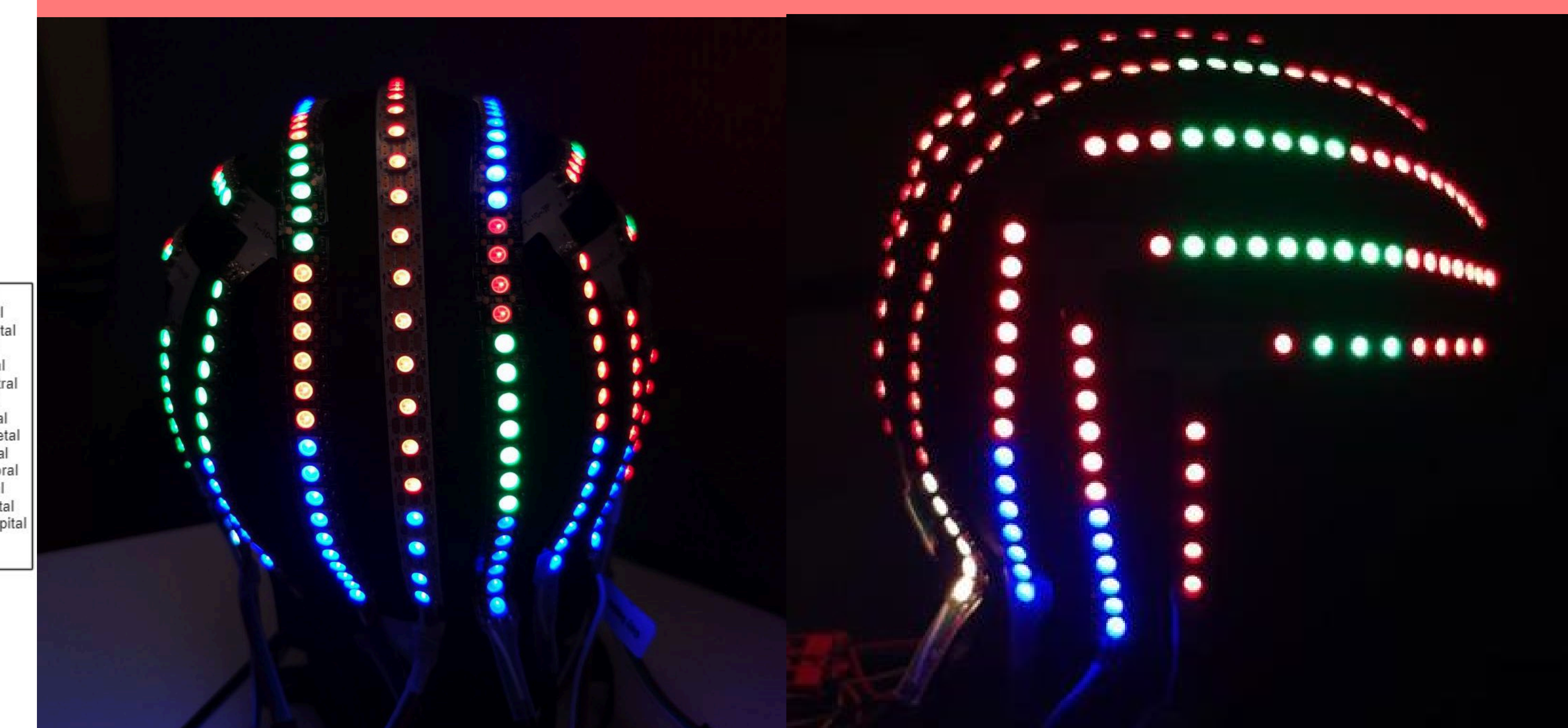

Figure 8. (a) Posterior and (b) right lateral views of the LED-embedded phantom head identifying the frequency band with the highest relative spectral power at each regional cluster.

Neural Benchmarking provides a real-time 3D heat map that simplifies complex EEG spectral data into interpretable spatial patterns. Alpha activity (blue) is mapped to occipital/posterior parietal regions and reflects relaxed wakefulness or visual idling, while beta activity (green) is mapped to the frontal lobe and indicates active cognitive load, focused attention, or motor execution.

ACKNOWLEDGEMENTS

We thank Capstone advisor Dr. Yuncheng Du along & the Cullen College of Engineering.