



# Restrictive Device for EMG-Guided Serious Game to Enhance Stroke Rehabilitation

Capstone Team: Axel Medina, Karla Resendez, Marcus Tubera, Yorliann Aviles

Facilitator: Dr. Jinsook Roh

University of Houston - Houston, TX



## Objective

To develop an EMG-guided serious game combined with a restrictive motion device to enable effective telerehabilitation for patients who have suffered stroke.

## Background

- Stroke is a leading cause of long-term disability
- Defect of the upper extremities after stroke is weakness due to coactivation of bicep and tricep
- Treatment post-stroke is physical therapy focusing on highly repetitive tasks and work-specific movements
- Rehabilitation involves time commitment and typically offered in clinic only
- Problem: Accessibility and Lack of Motivation**
- Serious games can add enjoyment and motivation
- Restraint device to control direction and speed of motion
- With minimal physician control, combination can be an effective remote setting treatment

## Methods

### Restrictive Device:

- AutoDesk Inventor Software
- 3D Printed using Creality Ender-3 V3 KE 3D Printer
  - Rail design was divided into 5 sections, each made to fit the dimensions on 3D printer bed
- Materials:
  - PLA for rail system
  - Steel bearing for moving mechanism
  - Wood for base and walls
- Measurements:
  - Device radius: 48.4 cm
  - Rail system inner measurements based on bearing and wood handle dimensions
  - 0.5 cm holes made on rails for attachment to walls



Figure 1. Restrictive motion device

### EMG Setup:

- System Components: EMG sensor, Link Shield, Arduino Shield, ELEGOO Uno R3
- Two muscle sensors attached to targeted muscles for elbow flexion and extension
- Sensors connected to MyoWare hub
- Processed data is output through serial port

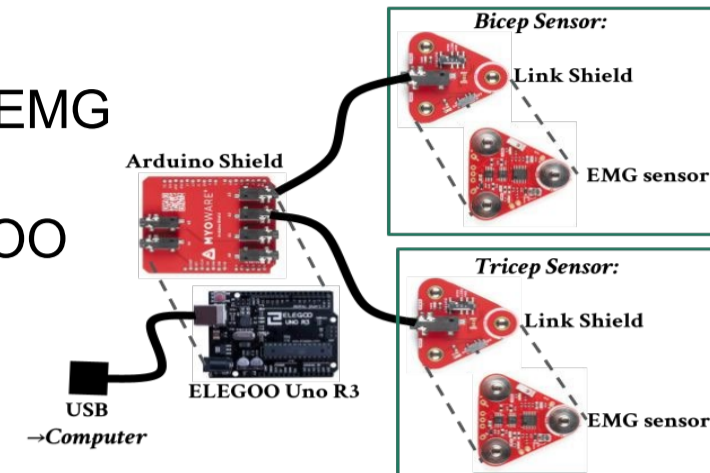

Figure 2. Diagram of Arduino components

### Serious Game:

- Galaga inspired game on Unity 3D using C# code
- Movement based on ratio of muscle activation
  - Elbow flexion moves player up
  - Elbow extension moves player down

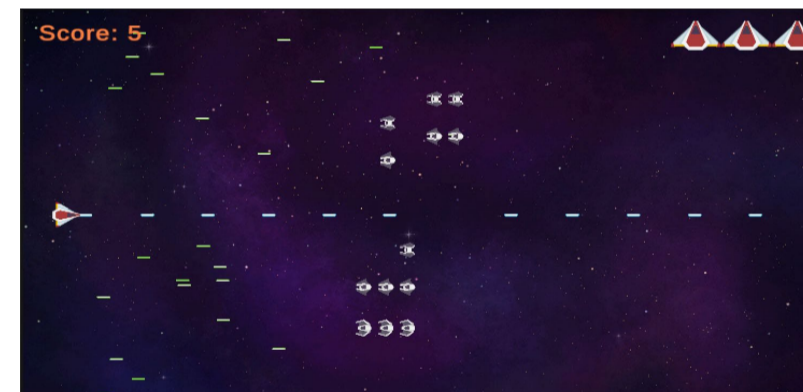

Figure 3. Gameplay of serious game

### Interface:

- Participant holds handle and views serious game
  - Block may be placed underneath elbow for support and proper alignment, depending on arm size
- Arm flexion and extension according to game cursor
- EMG sensors record bicep and tricep muscle activity separately
- MyoWare hub sends EMG data to computer
- Serious game reads EMG data and moves cursor

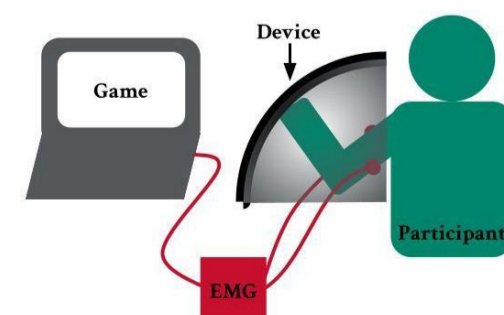

Figure 4. Interface diagram of components

## Results

- Effective symbiosis of restrictive device, participant's elbow flexion and extension, and EMG setup
- EMG setup effectively reads muscle activation of both bicep and tricep muscles during motion
- Independently, serious game functions as expected when manually inputting participant's arm movement

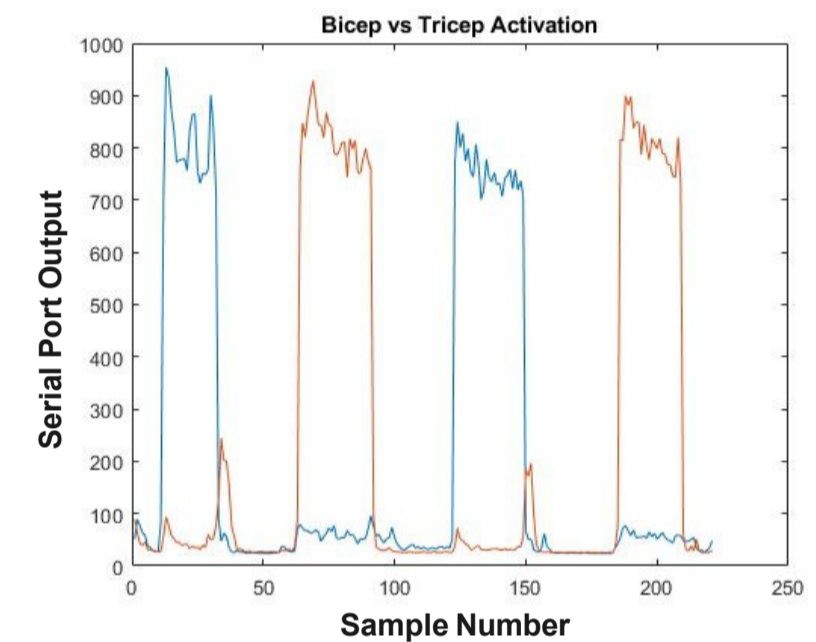

Figure 5. EMG data of bicep (blue) and tricep (orange) muscle activation over a period of time

## Conclusion

- Established functional restrictive motion device, EMG recording setup, and serious game to aid during participant's elbow flexion and extension
- Successful combination of restrictive device, and EMG setup during arm movement
- Lack of compatibility between serious game and EMG setup due to missing code to read EMG serial
- Future Directions:**
  - Integration of EMG setup and serious game
  - Test on stroke participant to gauge areas of growth in device and game development
  - Establish an interpretation of data for patients
  - Provide delivery method between patient's data and provider

## Acknowledgements

Our team would like to acknowledge Dr. Jinsook Roh and the REIGN lab team for their support in the development of this project.